

The information in this document is subject to change without notice and should not be construed as a commitment by ABB. ABB assumes no responsibility for any errors that may appear in this document.

Except as may be expressly stated anywhere in this document, nothing herein shall be construed as any kind of guarantee or warranty by ABB for losses, damages to persons or property, fitness for a specific purpose or the like.

In no event shall ABB be liable for incidental or consequential damages arising from use of this document.

This document and parts thereof must not be reproduced or copied without ABB's written permission, and contents thereof must not be imparted to a third party nor be used for any unauthorized purpose. Contravention will be prosecuted.

Additional copies of this document may be obtained from ABB at its then current charge.

© Copyright 2004 ABB ALL right reserved.

ABB Automation Technologies AB
Robotics
SE-721 68 Västerås
Sweden

Latest revision:
Prepared by, date: PR, 100507 | Approved by, date: AL,100517



Lab/Office:
PAW

SAFETY INTERFACE A/L/S
COPYRIGHT PAGE

Status:
Approved

Plant: =
Location: +
Sublocation: +

Document no.
3HEA802301-001

Rev. Ind
04

Page 1
Next 2
Total 15

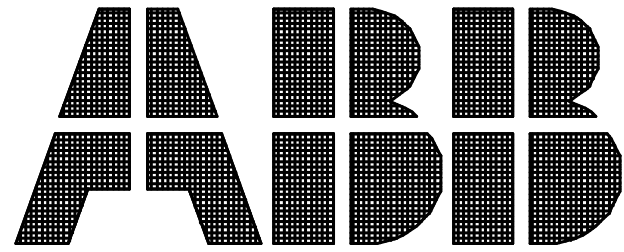

Description : SAFETY INTERFACE A/L/S
 Drawing number : 3HEA802301-001
 Drawing version : 04
 Date : 2010-05-17

Customer :
 Year of construction : 2010
 :
 :
 :
 :
 :
 :

Drawn by : PAW/PR
 Number of pages : 15
 :
 :
 :
 :

Latest revision:			Lab/Office:	SAFETY INTERFACE A/L/S	Status:	Plant: =	Rev. Ind	Page 2
			PAW		TITLE PAGE	Approved		Location: +
Prepared by, date: PR, 100507	Approved by, date: AL,100517				Document no.	Sublocation:+	04	Total 15
					3HEA802301-001			

We reserve all rights in this document and in the information contained therein. Reproduction, use or disclosure to third parties without express authority is strictly forbidden. © Copyright 2003 ABB

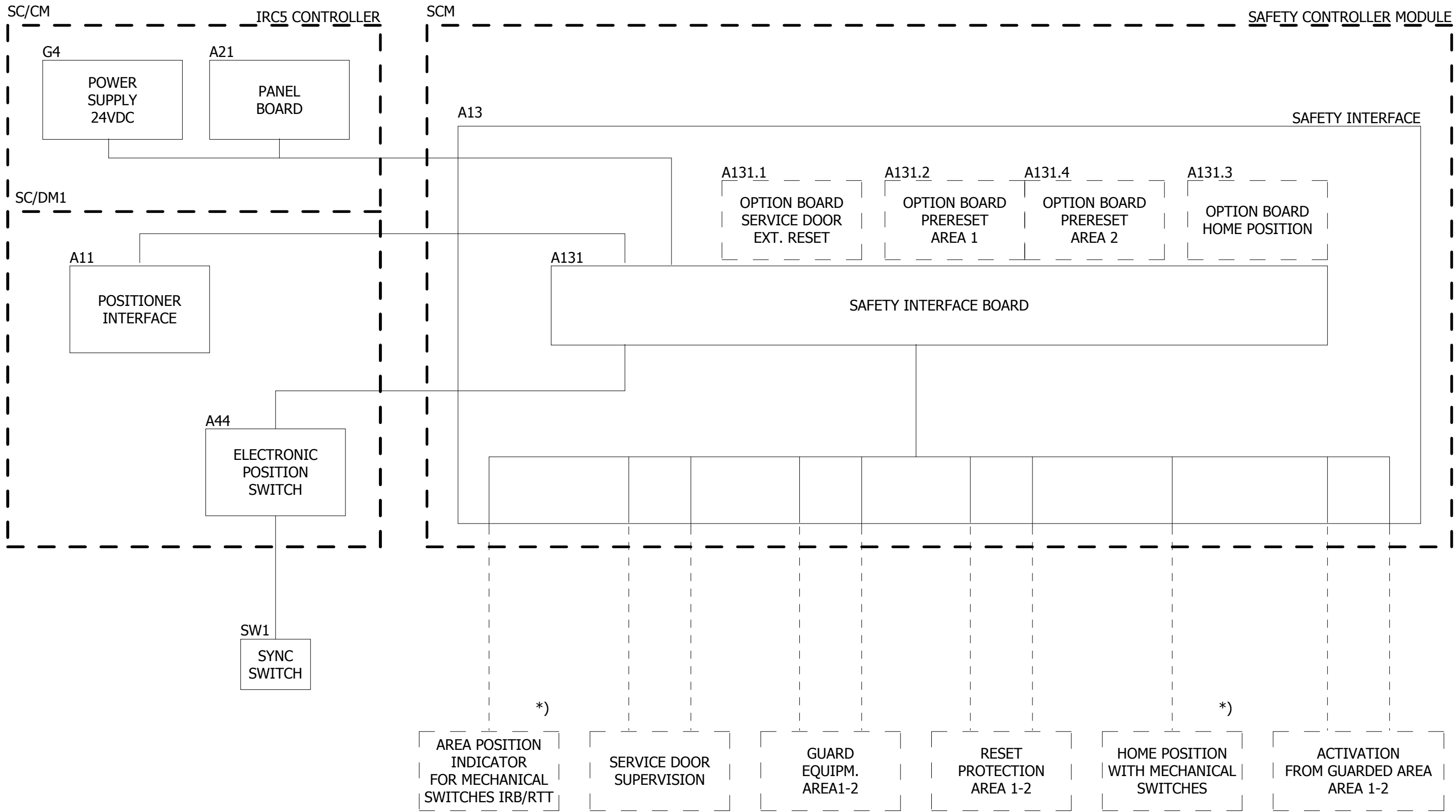

*) NOT TOGETHER WITH ELECTRONIC POSITION SWITCH.

Latest revision: Rev. 04:Electronic Position Switch added.		ABB	Lab/Office: PAW	SAFETY INTERFACE A/L/S BLOCK DIAGRAM	Status: Approved	Plant: = Location: + Sublocation: +
Prepared by, date: PR, 100507	Approved by, date: AL,100517		Document no. 3HEA802301-001		Rev. Ind 04	Page 4 Next 5 Total 15

CONNECTED WITH AWG 18 BU,
IF NO OTHER NOTATION

SC/
CM

IRCS CONTROLLER

SEE EL.DWGS FOR THE IRC5 CONTROLLER

- *) CONNECTED TO XT31 IN SYSTEMS WITHOUT CUSTOMER POWER SUPPLY
- **) RESISTANCE 120 Ohm SHALL ALWAYS BE CONNECTED IN THE FIRST AND THE LAST CONNECTOR IN THE CANBUS CIRCUIT

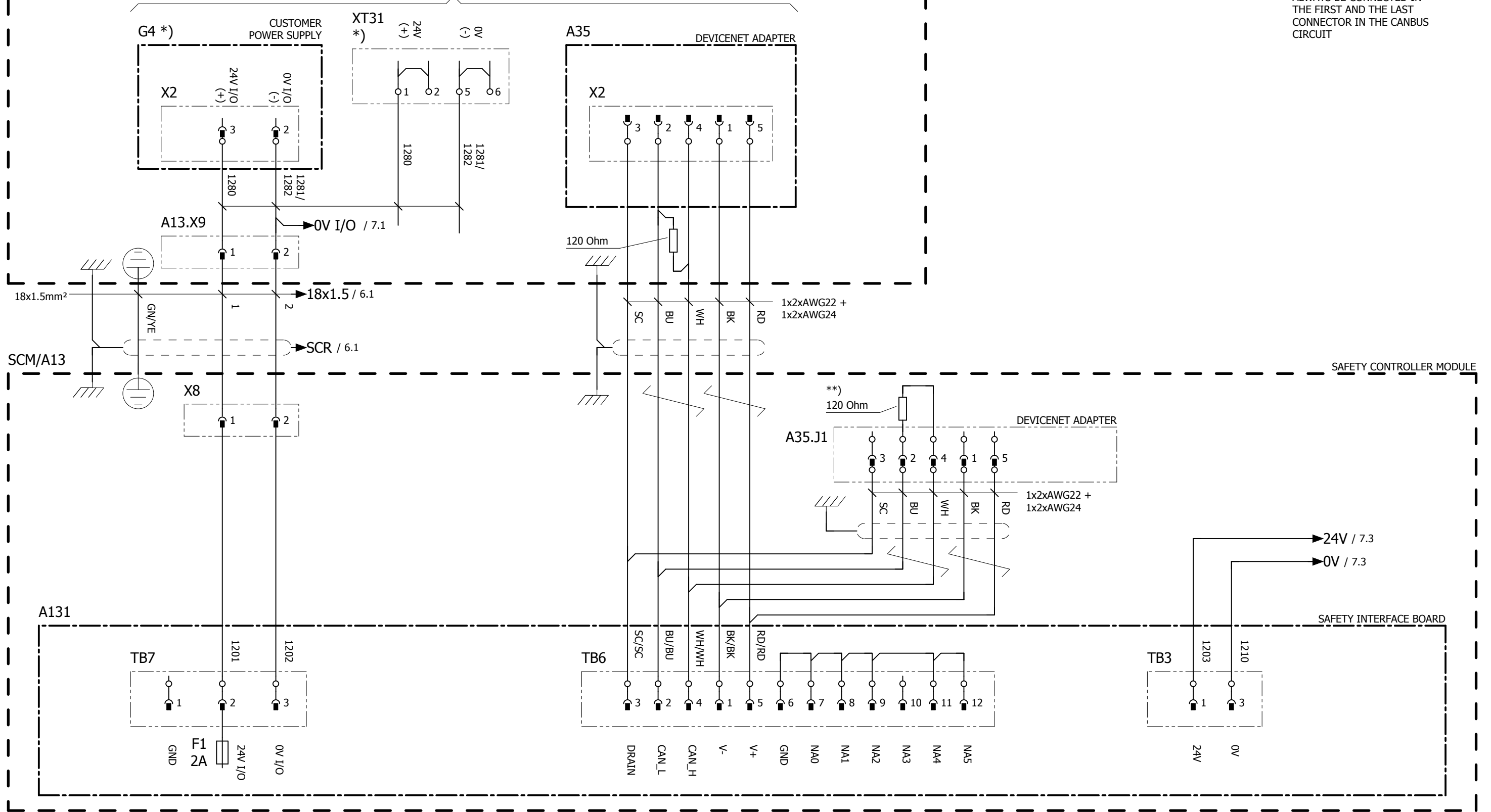

Latest revision:
Rev. 03:G6 deleted.XT31 added(2-3)

Prepared by, date: PR, 100507

Approved by, date: AL,100517



Lab/Office:
PAW

SAFETY INTERFACE A/L/S
MAINS / CAN BUS

Status:
Approved

Plant: =
Location: +
Sublocation: +

Document no.
3HEA802301-001 04

Rev. Ind Page 5
Next 6
Total 15

CONNECTED WITH AWG 18 BU,
IF NO OTHER NOTATION

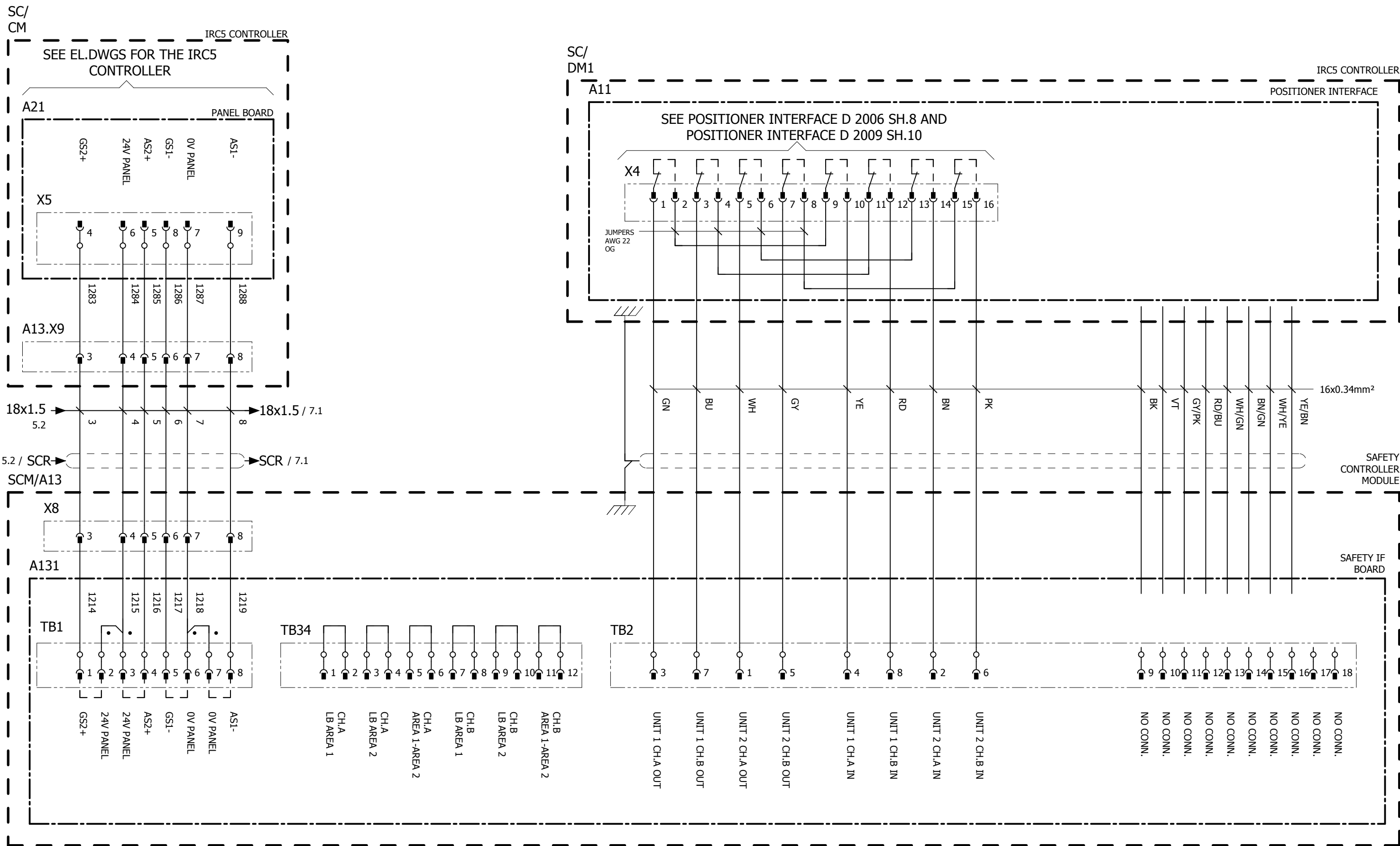

Latest revision:

ABB Lab/Office:
PAW

SAFETY INTERFACE A/L/S
RUN CHAIN A/L/S

Status: **Approved**
Plant: =
Location: +
Sublocation: +

Prepared by, date: PR, 100507 Approved by, date: AL,100517

Document no. **3HEA802301-001** Rev. Ind **04** Page 6
Next 7
Total 15

We reserve all rights in this document and in the information contained therein. Reproduction, use or disclosure to third parties without express authority is strictly forbidden. © Copyright 2003 ABB

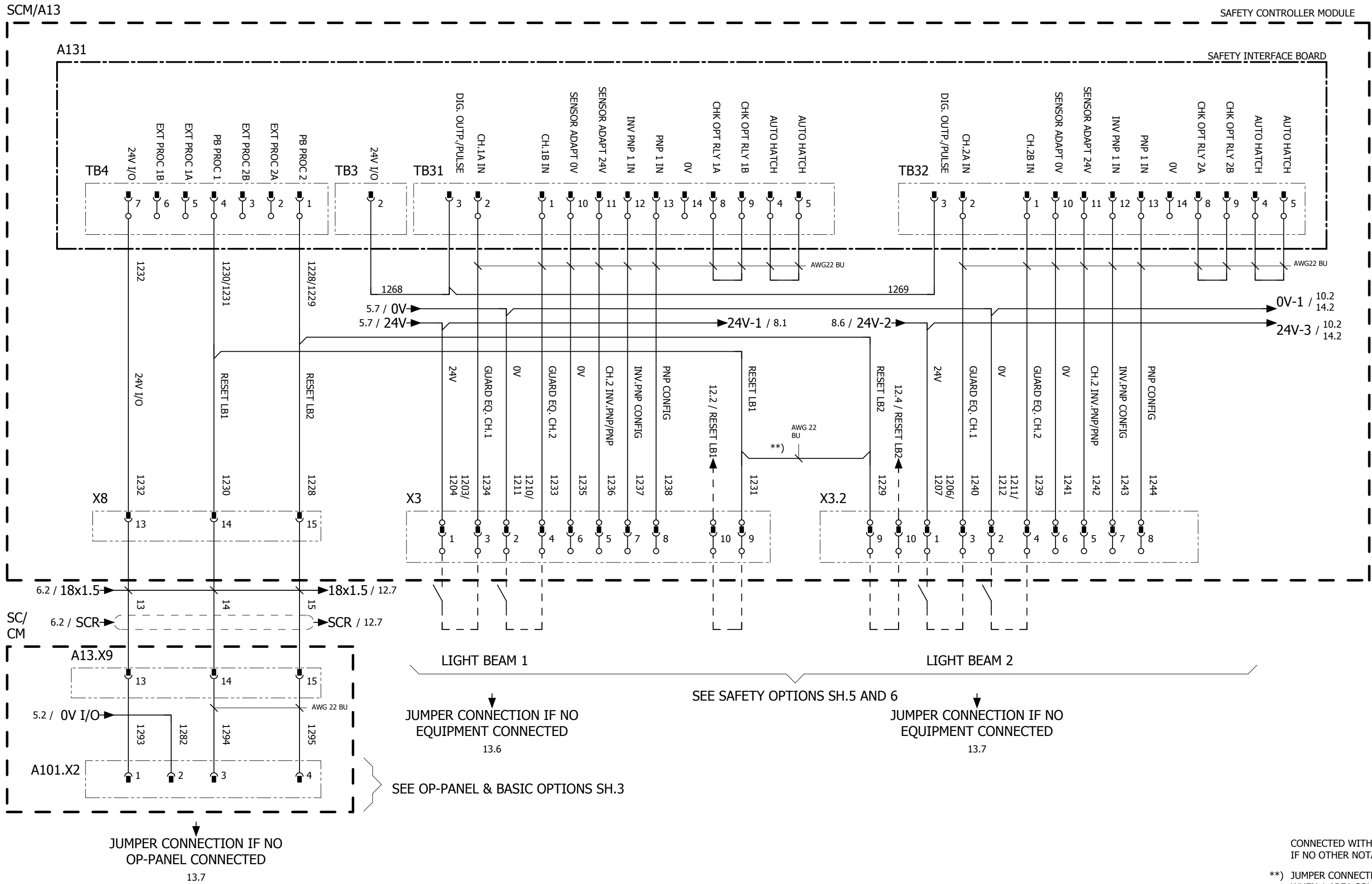

We reserve all rights in this document and in the information contained therein. Reproduction, use or disclosure to third parties without express authority is strictly forbidden. © Copyright 2003 ABB

Latest revision:	 Lab/Office: PAW	SAFETY INTERFACE A/L/S GUARD EQUIPMENT LB TYPE MSLZ AND M4000/M40Z	Status: Approved	Plant: = Location: + Sublocation: +	Document no. 3HEA802301-001	Rev. Ind	Page 7
Prepared by, date: PR, 100507			Approved by, date: AL,100517	04		Next 8	Total 15

We reserve all rights in this document and in the information contained therein. Reproduction, use or disclosure to third parties without express authority is strictly forbidden. © Copyright 2003 ABB

SCM/A13

SAFETY CONTROLLER MODULE

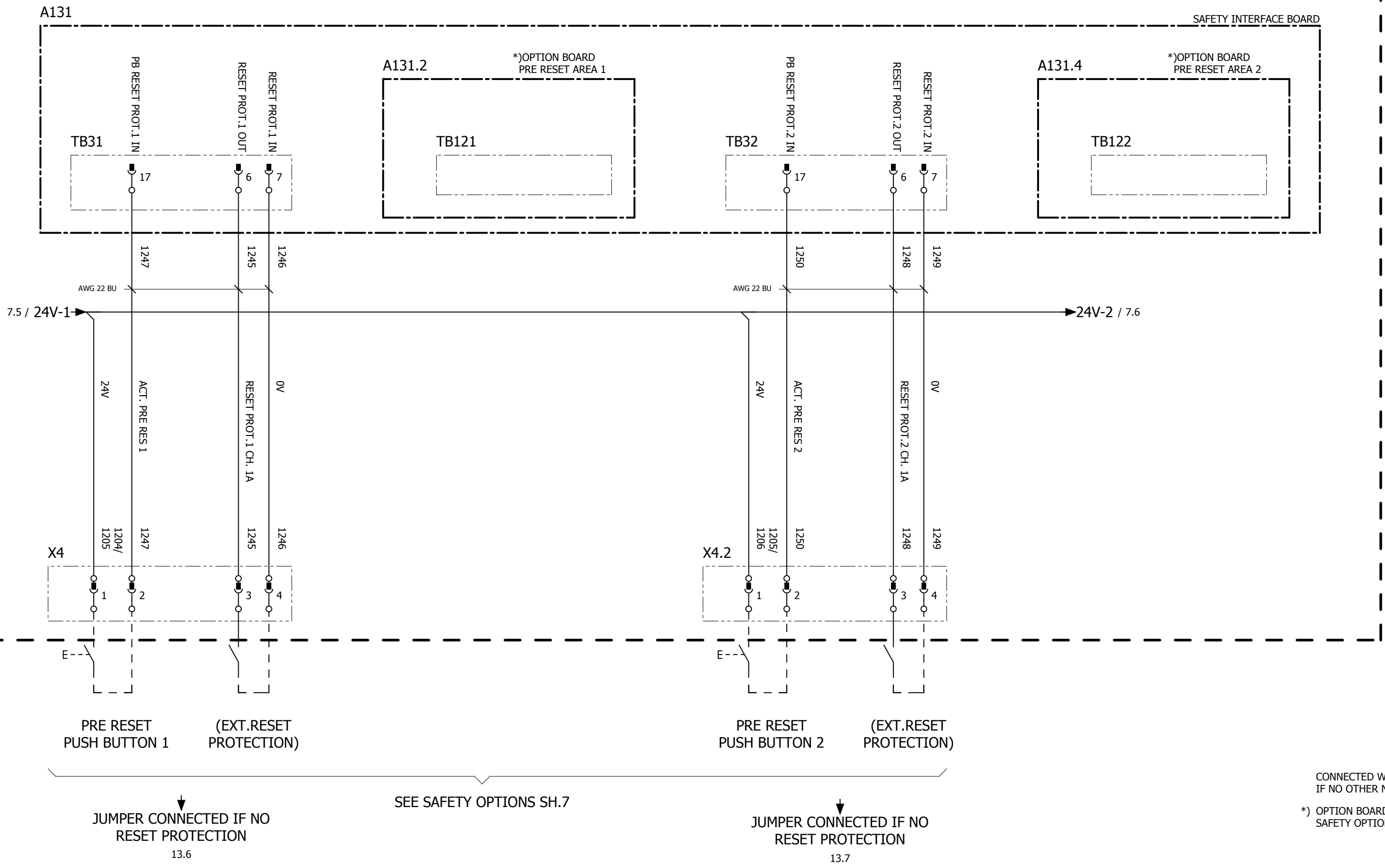

CONNECTED WITH AWG 18 BU,
IF NO OTHER NOTATION
*) OPTION BOARD ONLY IF
SAFETY OPTION PRE RESET PB

Latest revision:	 Lab/Office: PAW	SAFETY INTERFACE A/L/S RESET PROTECTION	Status: Approved	Plant: =	Page 8
			Document no. 3HEA802301-001	Location: +	
Prepared by, date: PR, 100507	Approved by, date: AL,100517			Sublocation: +	Total 15

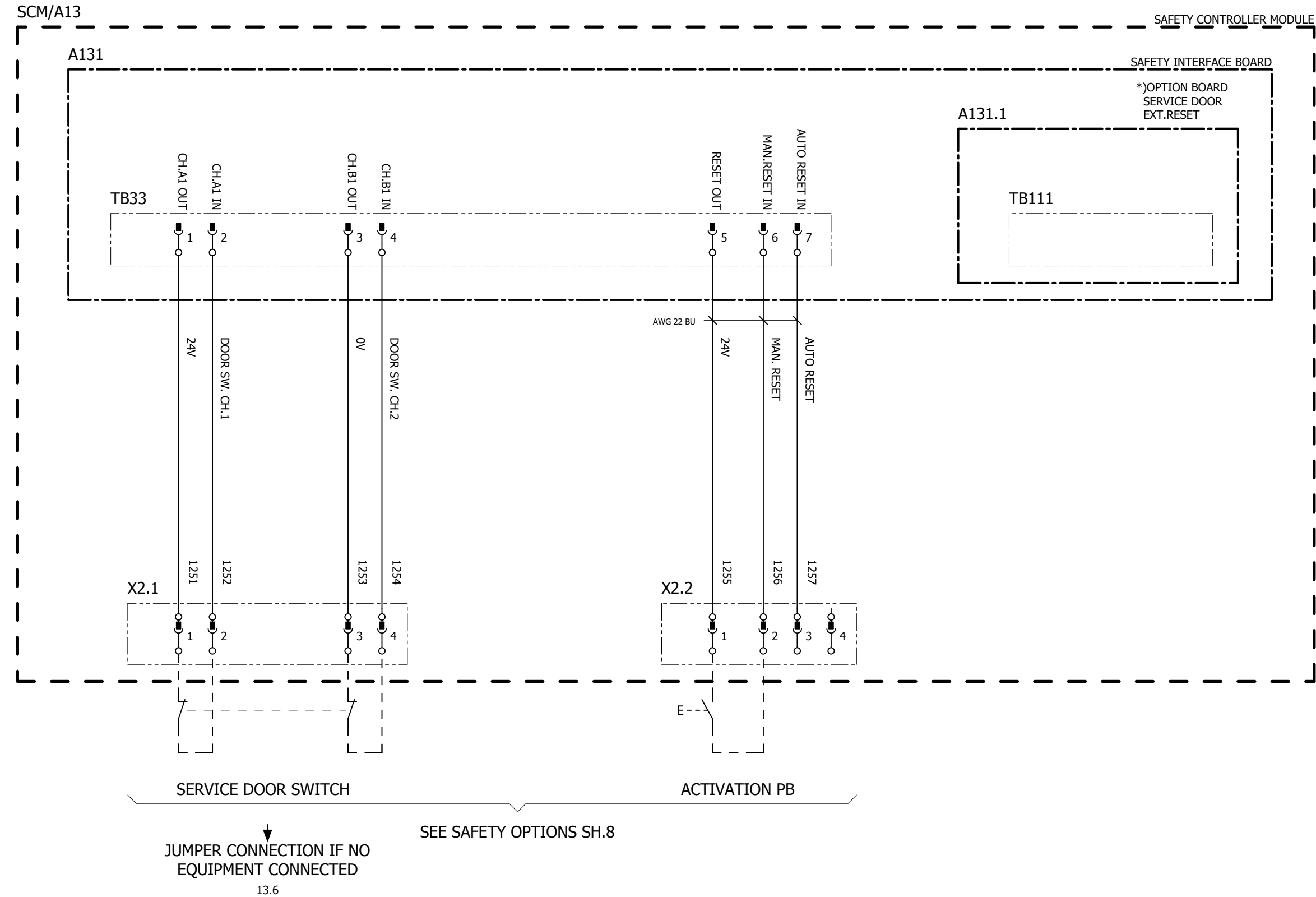

CONNECTED WITH AWG 18 BU,
IF NO OTHER NOTATION

*) OPTION BOARD ONLY
IF SAFETY OPTION
EXT. RESET PB

We reserve all rights in this document and in the information contained therein. Reproduction, use or disclosure to third parties without express authority is strictly forbidden. © Copyright 2003 ABB

Latest revision:	ABB	Lab/Office: PAW	SAFETY INTERFACE A/L/S SERVICE DOOR SUPERVISION	Status: Approved	Plant: = Location: + Sublocation: +
Prepared by, date: PR, 100507		Approved by, date: AL,100517		Document no. 3HEA802301-001	Rev. Ind 04

CONNECTED WITH AWG 18 BU,
IF NO OTHER NOTATION

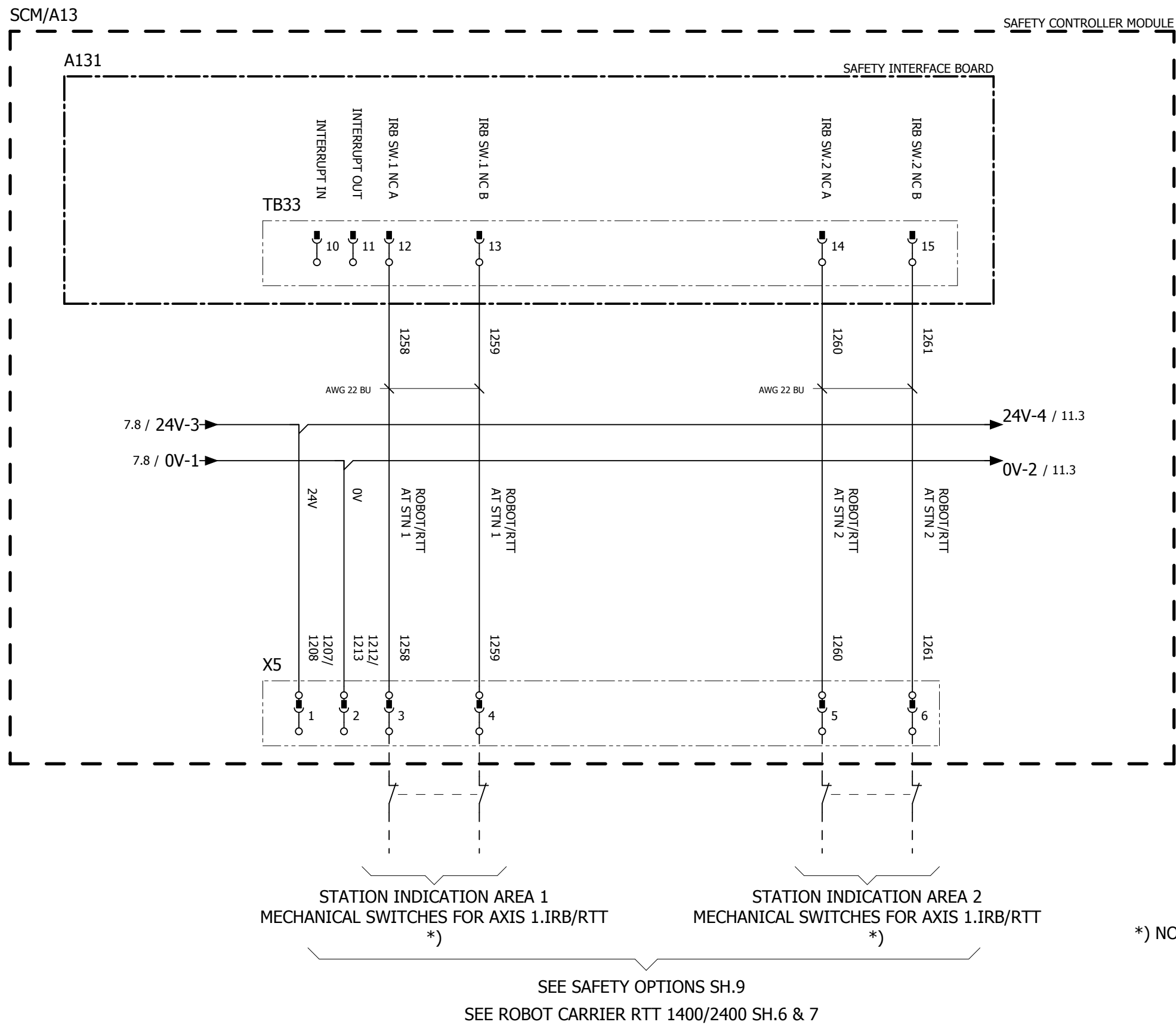

*) NOT TOGETHER WITH ELECTRONIC POSITION SWITCH.

Latest revision:
Rev. 04:Note *) added.

Prepared by, date: PR, 100507

Approved by, date: AL,100517



Lab/Office:
PAW

SAFETY INTERFACE A/L/S
STATION INDICATION WITH
MECHANICAL SWITCHES AXIS 1,IRB

Status:
Approved

Plant: =
Location: +
Sublocation: +

Document no.
3HEA802301-001

Rev. Ind	Page 10
04	Next 11
	Total 15

CONNECTED WITH AWG 18 BU,
IF NO OTHER NOTATION

*) OPTION BOARD ONLY
IF SAFETY OPTION
HOME/TRANSPORT POSITION

SCM/A13

SAFETY CONTROLLER MODULE

A131

SAFETY INTERFACE BOARD

A131.3

*)OPTION BOARD
HOME POS./
TRANSP.POS.

TB112

TB33

CH.A2 IN

CH.B2 IN

8

9

AWG 22 BU

AWG 22 BU

10.5 / 24V-4

10.5 / 0V-2

24V-5 / 12.5

24V

SAFE POS.CH.1

0V

SAFE POS.CH.2

1208/
1209

1262

1213

1263

X6

1

2

5

3

4

6

POSITION SWITCH 1
MECHANICAL SWITCH FOR AXIS 1.IRB
*)

POSITION SWITCH 2
MECHANICAL SWITCH FOR AXIS 1.IRB
*)

*) NOT TOGETHER WITH ELECTRONIC POSITION SWITCH.

SEE SAFETY OPTIONS SH.10

Latest revision:
Rev. 04:Note *) added.

Prepared by, date: PR, 100507

Approved by, date: AL,100517



Lab/Office:
PAW

SAFETY INTERFACE A/L/S
HOME POSITION WITH MECHANICAL
SWITCHES AXIS 1,IRB

Status:
Approved

Plant: =
Location: +
Sublocation: +

Document no.
3HEA802301-001

Rev. Ind
04
Page 11
Next 12
Total 15

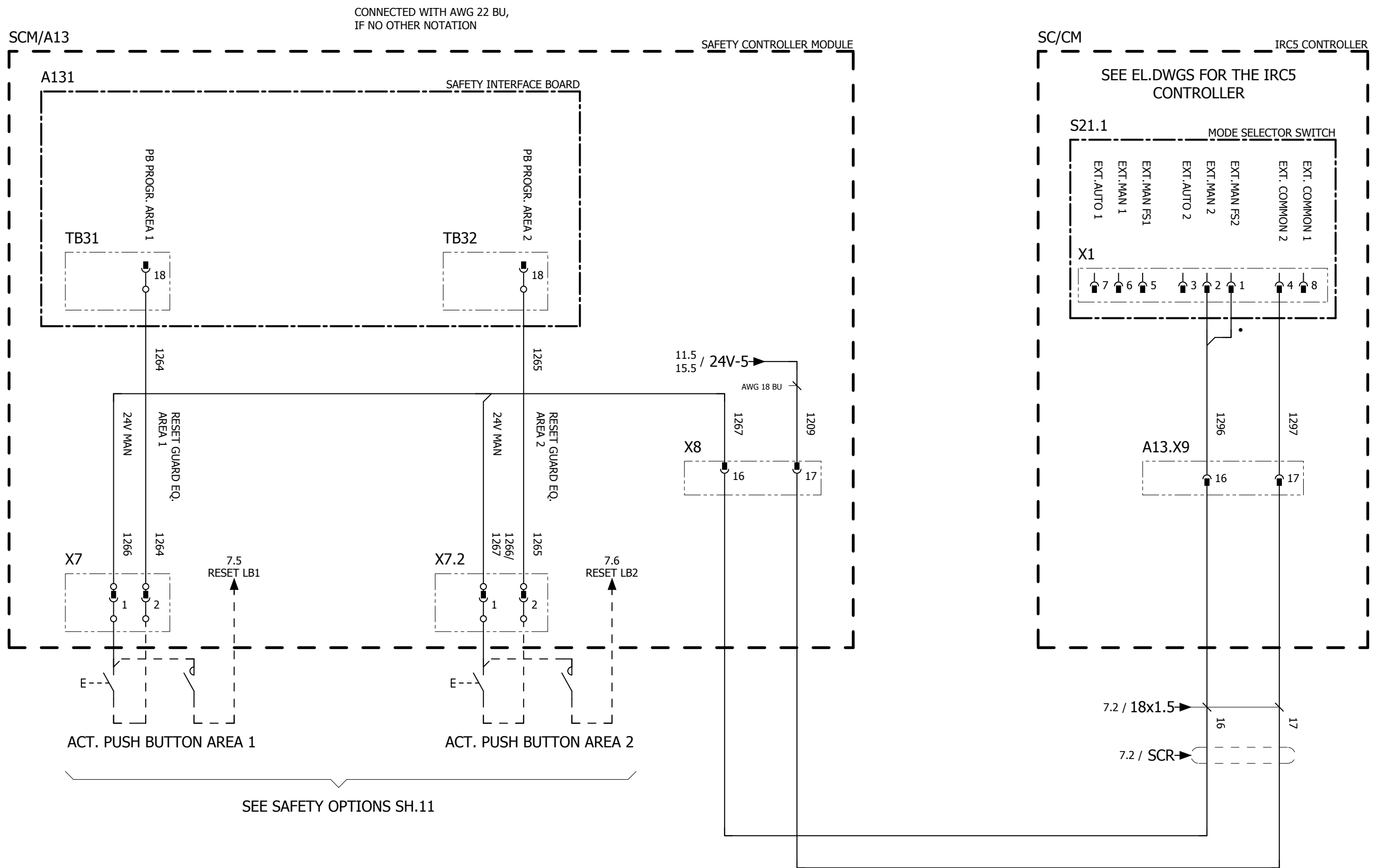

We reserve all rights in this document and in the information contained therein. Reproduction, use or disclosure to third parties without express authority is strictly forbidden. © Copyright 2003 ABB

Latest revision:			Lab/Office: PAW	SAFETY INTERFACE A/L/S ACTIVATION FROM GUARDED AREAS	Status: Approved	Plant: = Location: + Sublocation: +
Prepared by, date: PR, 100507	Approved by, date: AL,100517				Document no. 3HEA802301-001	Rev. Ind 04 Page 12 Next 13 Total 15

CONNECTED WITH AWG 18 BU,
IF NO OTHER NOTATION

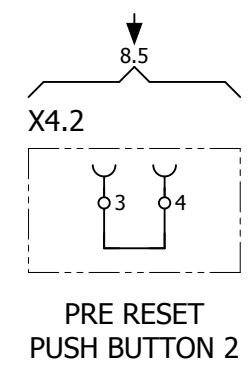
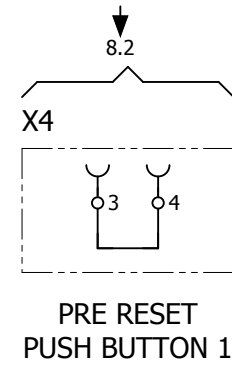
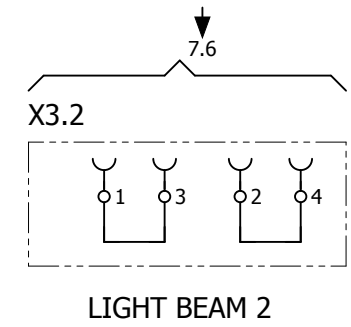
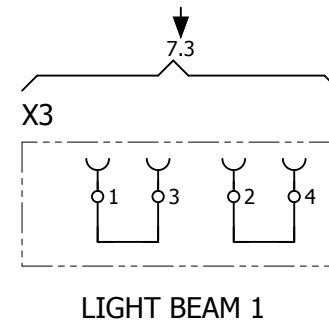
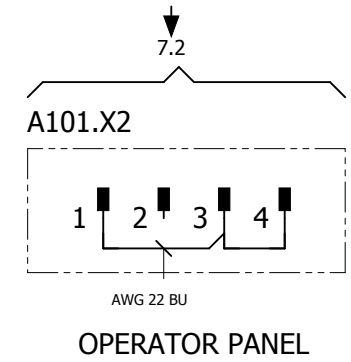
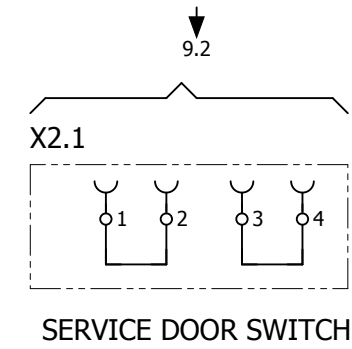
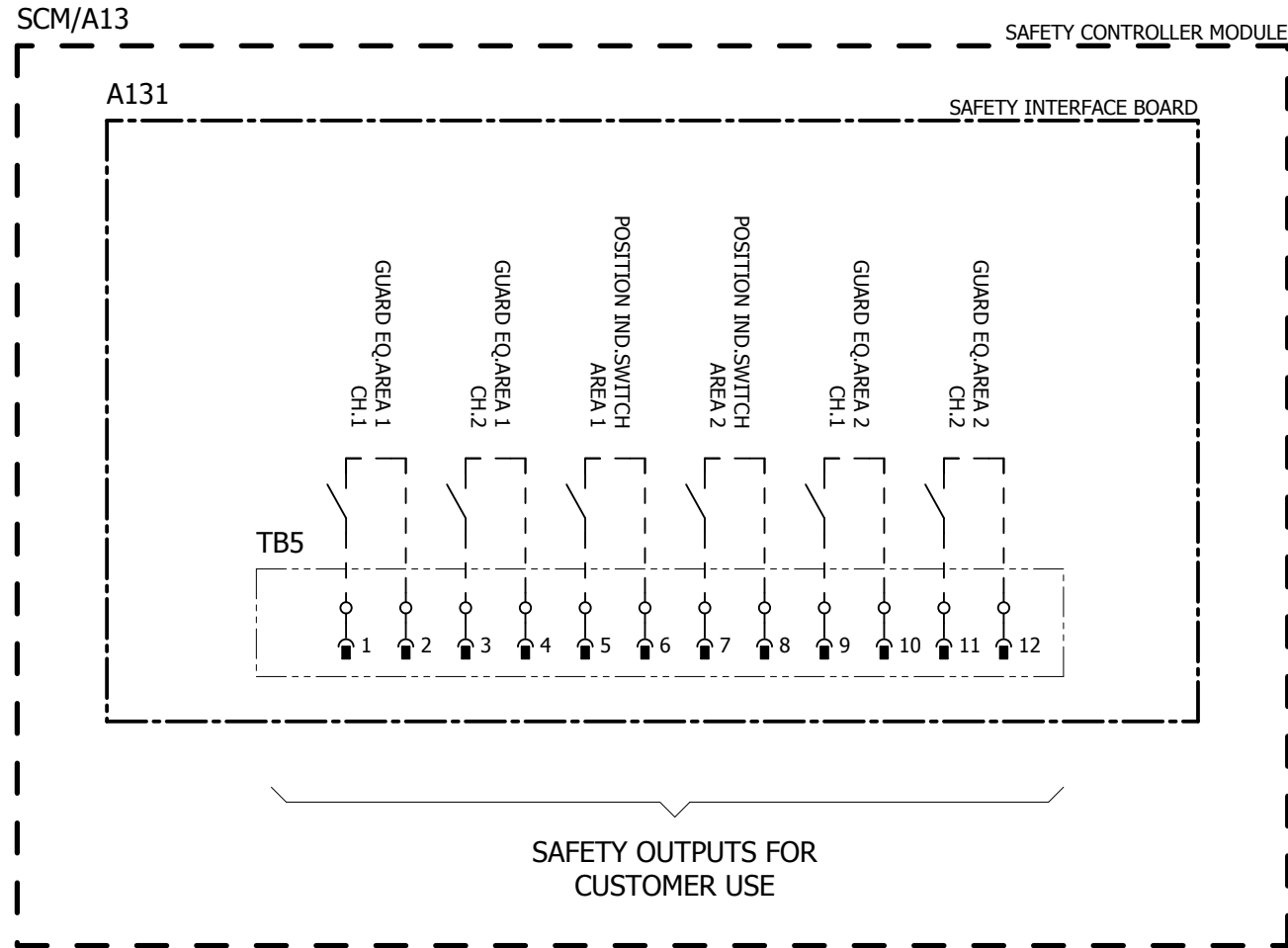

Latest revision:

Prepared by, date: PR, 100507

Approved by, date: AL,100517

ABB Lab/Office:
PAW

SAFETY INTERFACE A/L/S
JUMPERS CONNECTIONS /
CUSTOMER CONNECTIONS

Status: Approved

Plant: =
Location: +
Sublocation: +

Document no. 3HEA802301-001

Rev. Ind 04

Page 13
Next 14
Total 15

CONNECTED WITH AWG 18 BU,
IF NO OTHER NOTATION

RL1:ROBOT AT STN. 1
RL2:ROBOT AT STN. 2

SCM/A13

SAFETY CONTROLLER MODULE

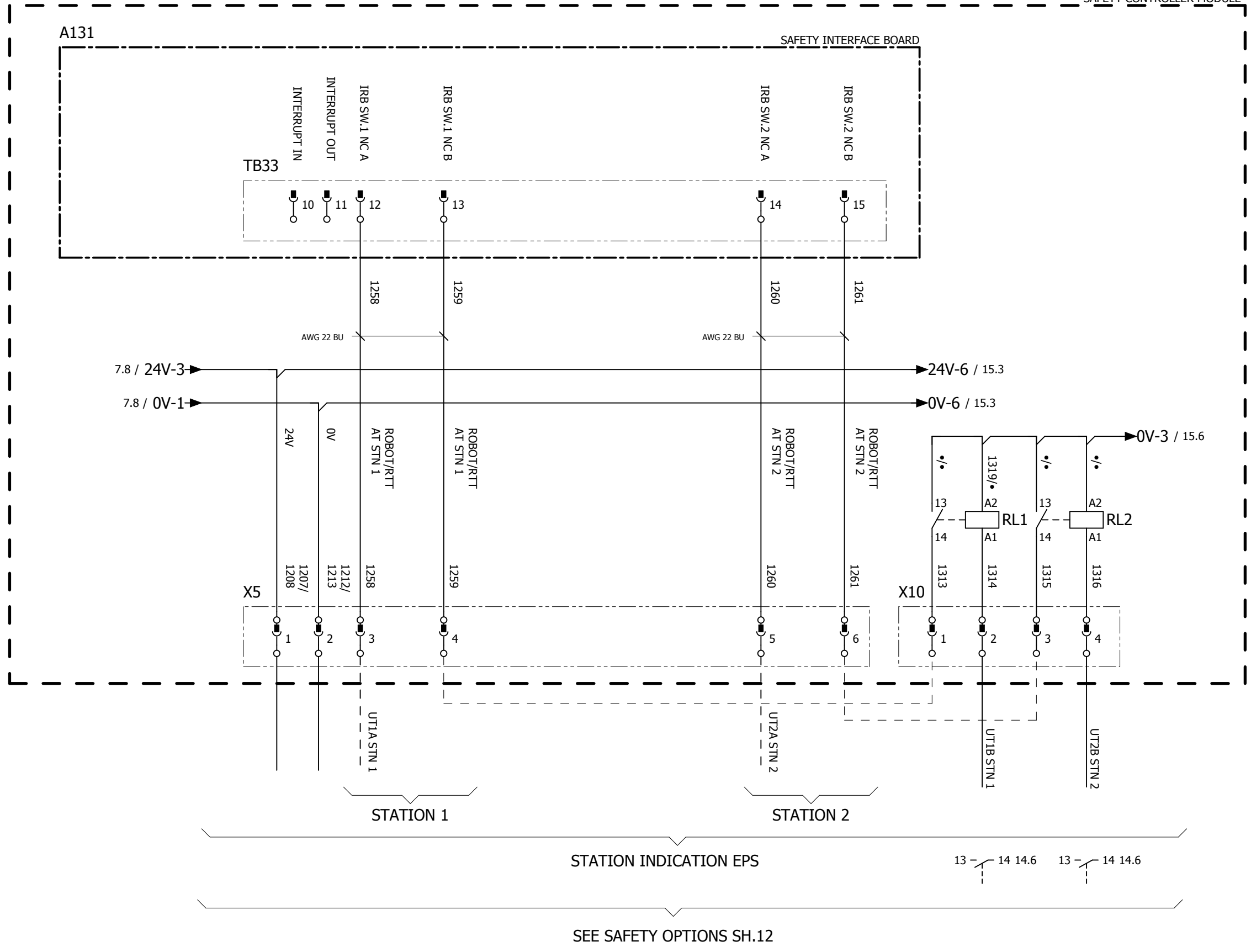

We reserve all rights in this document and in the information contained therein. Reproduction, use or disclosure to third parties without express authority is strictly forbidden. © Copyright 2003 ABB

Latest revision:
Rev. 04:Page 14 added.

Prepared by, date: PR, 100507 Approved by, date: AL,100517

ABB Lab/Office:
PAW

SAFETY INTERFACE A/L/S
STATION INDICATION WITH
EPS FOR AXIS 1,IRB

Status: Approved	Plant: = Location: + Sublocation: +
Document no. 3HEA802301-001	Rev. Ind 04
	Page 14 Next 15 Total 15

We reserve all rights in this document and in the information contained therein. Reproduction, use or disclosure to third parties without express authority is strictly forbidden. © Copyright 2003 ABB

CONNECTED WITH AWG 18 BU,
IF NO OTHER NOTATION

*) OPTION BOARD ONLY
IF SAFETY OPTION
HOME/TRANSPORT POSITION

RL3:ROBOT IN HOME POSITION

SCM/A13

SAFETY CONTROLLER MODULE

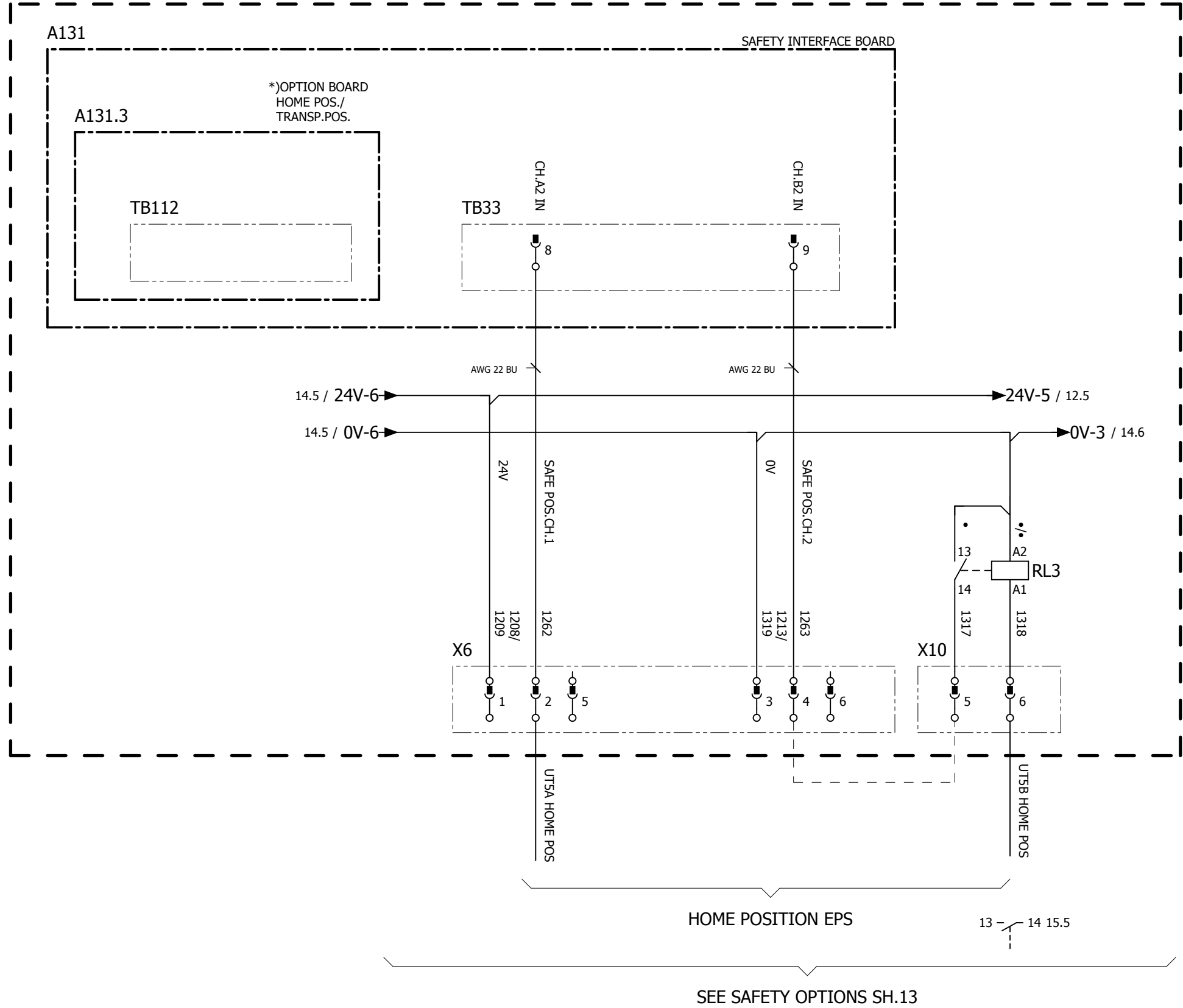

HOME POSITION EPS

SEE SAFETY OPTIONS SH.13

Latest revision:
Rev. 04:Page 15 added.

Prepared by, date: PR, 100507

Approved by, date: AL,100517



Lab/Office:
PAW

SAFETY INTERFACE A/L/S
HOME POSITION WITH EPS
FOR AXIS 1,IRB

Status:
Approved

Document no.
3HEA802301-001

Plant: =
Location: +
Sublocation: +

Rev. Ind Page 15
Next
Total 15